

A C S II - 1 0 0 0
A C S II - 2 0 0 0
INSTRUCTION MANUAL

SURFACE TEMPERATURE CALIBRATION SYSTEM

A E - 1 0 0 2 3 0
3rd Edition July 2023

ANRITSU METER CO., LTD.

<http://www.anritsu-meter.co.jp>

— Contents —

No.		Page
1.	Unpacking	4
2.	Name of Component	4
2-1.	Control Unit	4
2-2.	Calibration Unit	4
3.	Installation	6
4.	Operation Check	7
5.	Operation	8
5-1.	Turning on/off the power and heater	8
5-2.	Temperature Control	9
5-2-1.	Setting the surface temperature of the block	9
5-2-2.	Setting the PID values	10
	● Auto tune (Recommended mode)	10
	● Manual PID setting mode	11
6.	Calibration tutorial	13
6-1.	Introduction	13
6-2.	Environmental Conditions	13
6-3.	Warm Up	13
6-4.	Calibration Probe	14
7.	Specifications	15
	● Overall Accuracy	15
	● Control Unit	15
	● Calibration Unit	15

1. Unpacking

Please make sure that when performing the unpacking of the product that contains the following items.

Name	Quantity	Name	Q(Length)
Control Unit	1	Power cord	1(2m)
Calibration Unit	1	Heater Cable	1(1m)
Protective cover calibration Block	1	Sensor Cable	1(1m)
Instruction Manual	1		

2. Name of Component

2-1. Control Unit

ACS II – 1000 / 2000

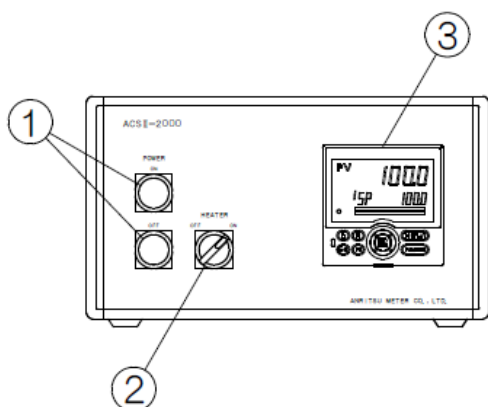

- ① Power Switch
- ② Heater Switch
- ③ Display

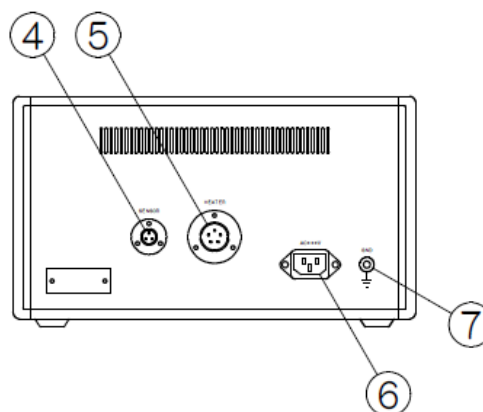

- ④ Connector for Sensor Cable
- ⑤ Connector for Heater Cable
- ⑥ Power Connector
- ⑦ Ground

2-2. Calibration Unit

ACS II – 1000

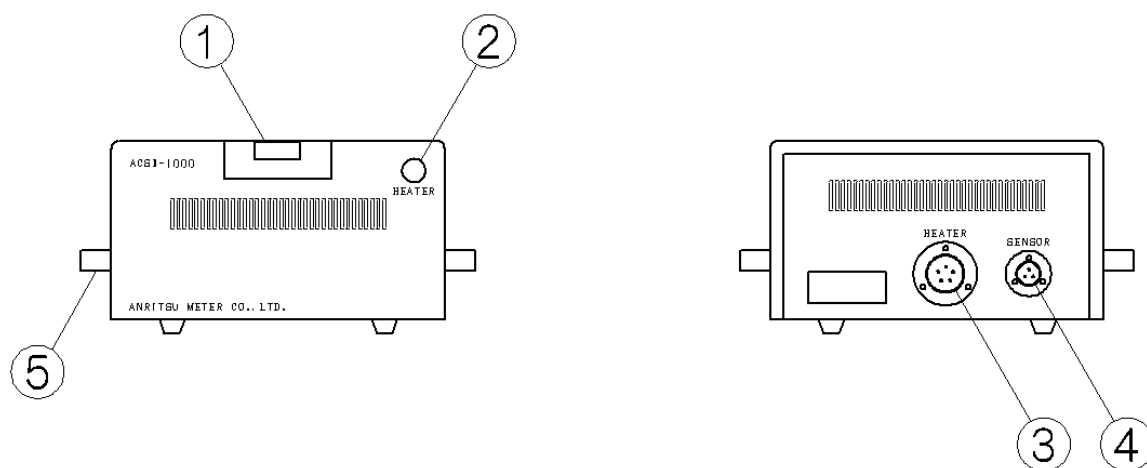

ACS II – 2000

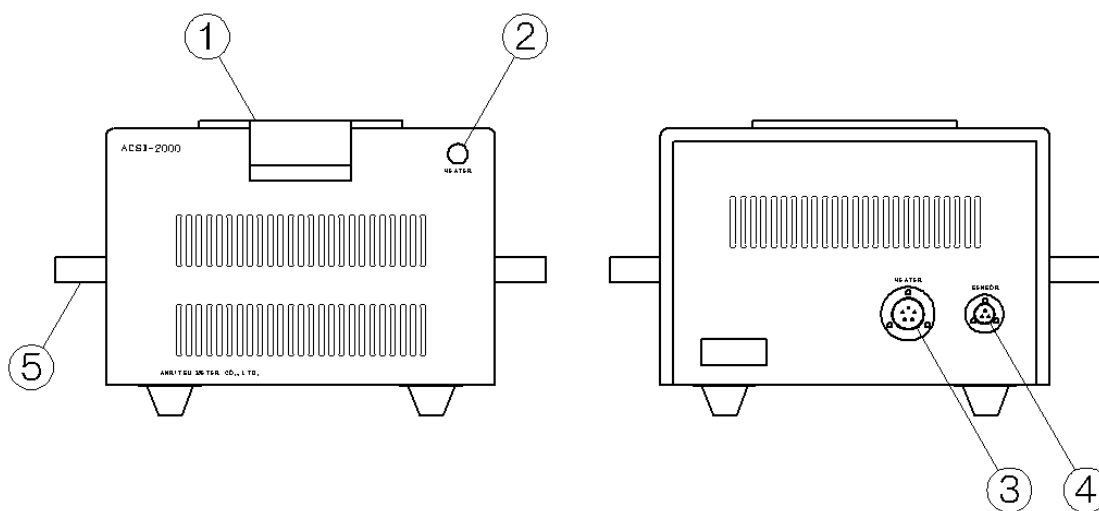

- ① Calibration Block
- ② Heater Indicator
- ③ Connector for Heater Cable

- ④ Connector for Sensor Cable
- ⑤ Handle

3. Installation

Use the following procedure to connect Calibration Unit to Control Unit and line power source. Connect the female end of the power cord to the AC receptacle on the rear panel and the other end of the power cord to a grounded AC outlet.

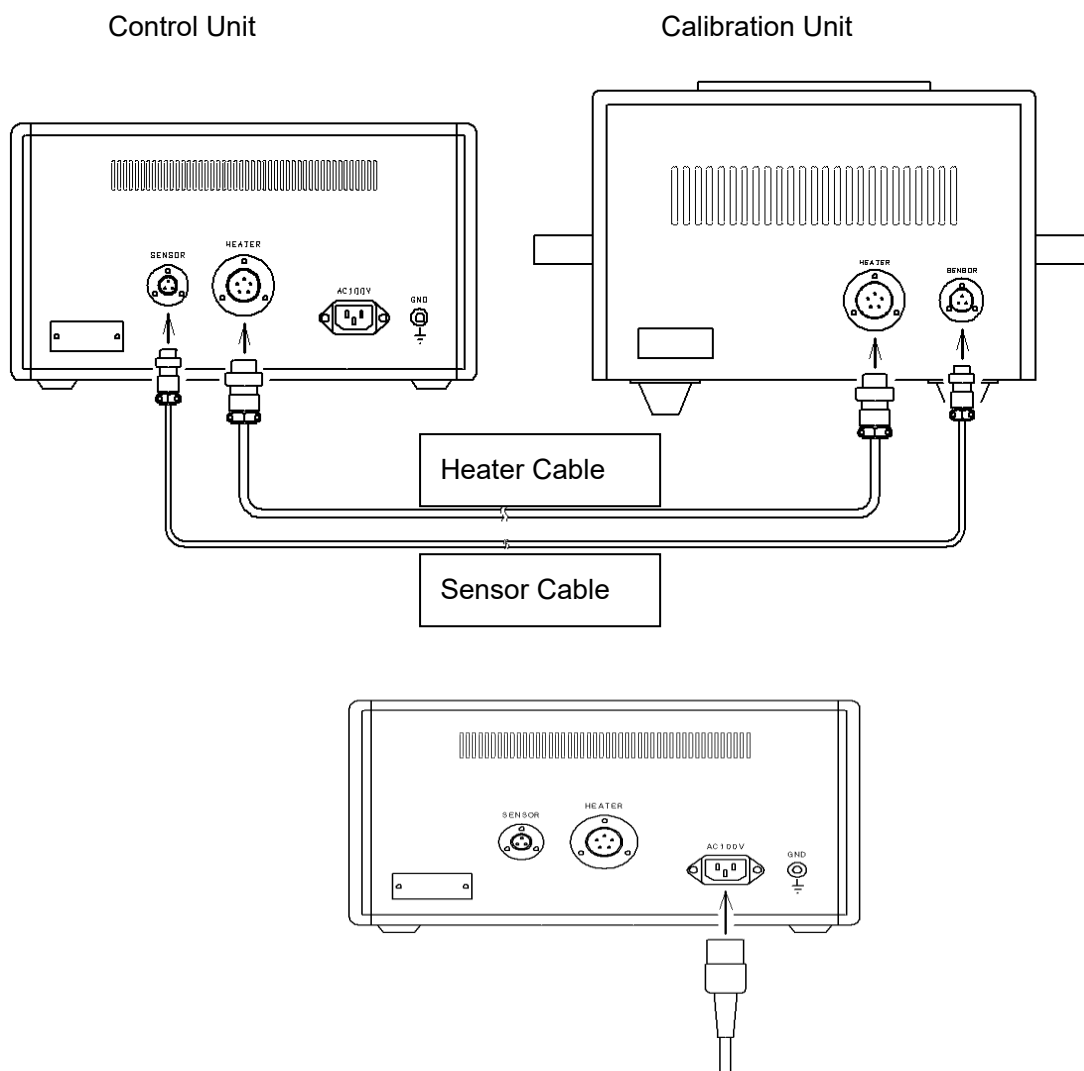

—CAUTION—

Be sure the power line voltage agrees with the indicated value on the rear panel of the instrument. Failure to observe this warning may result in instrument damage.

—WARNING—

ACS II - series control unit is equipped with a 3-wire power cord designed to be used with grounded outlets. When the power connections are made, instrument chassis is connected power line ground. Failure to use a properly grounded outlet may result in personal injury or death because of electric shock.

—WARNING—

If power consumption of the instrument exceeds each provided value, Breaker wrong with the instrument, contact the place of purchase.

4. Operation Check

Turn the “POWER” switch and “HEATER” switch of the controller unit ON. The indicator of the controller unit displays the surface temperature of the block of the calibration block unit with the preset temperature below.

The green lamp at the upper left of the indicator is a heater control lamp.

When the heater switch of the controller unit is ON, it synchronizes the heater operation lamp of the calibration block unit (heater control ON).

When the heater switch is OFF, the heater operation lamp is turned off regardless of the state of the heater control lamp (heater control OFF).

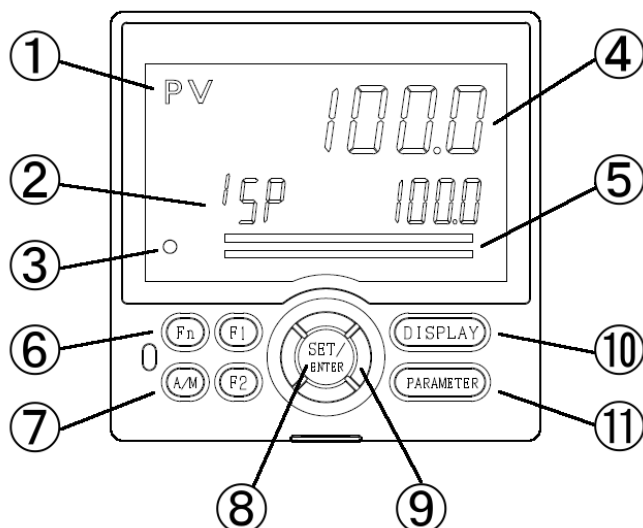

Name	Function	Name	Function
① PV	Indicated value display	⑥ Fn	PID parameter display switch key
② SP	Preset temperature display	⑦ F1	Not operate
Out	Control output display	F2	
P (several ones)	Display of various parameters	A/M	
③ Red luminescence	Auto tune display	⑧ SET/ENTER	Selection/ Enter key
④ Upper gauge	Indicated value level display Scale of 0 to 500°C	⑨ Arrow	Display/numeral change keys
⑤ Lower gauge	Control output level display Scale of 0 to 100%	⑩ DISPLAY	SP (preset temperature), Out (output value)Display switch key
		⑪ PARAMETER	Parameter switch key

—CAUTION—

On the controller, it is possible to manipulate parameters for temperature control (heater control) and correction of the combined sensor. Do not manipulate the internal parameters because temperature control of the calibration block may not be executed normally if some parameters are changed.

5. Operation

5-1. Turning on/off the power and heater

When you turn the “POWER” switch of the controller unit ON, power is applied and the indicator displays the surface temperature and the preset temperature of the calibration block as shown in Fig.5-1.

When you turn the “POWER” switch off, the power is turned off and the indication disappears.

When you turn the “HEATER” switch ON, the heater is heated. When the switch is turned OFF, the heater is not heated.

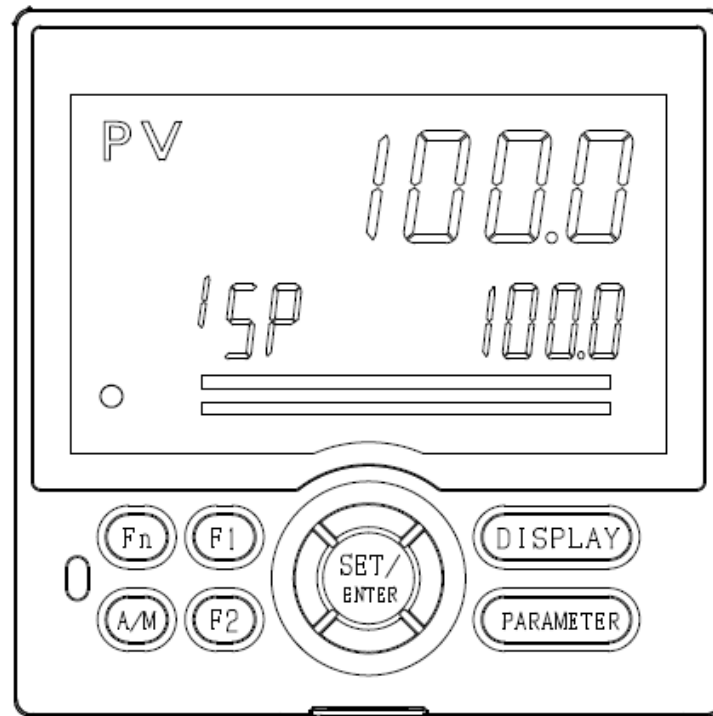

Fig.5-1.

—CAUTION—

- Be careful with the surface of the calibration block because it may be hot even after the “HEATER” switch is turned OFF.
- For power off, turn the “POWER” switch OFF when the surface temperature of the calibration block becomes low enough after the “HEATER” switch is turned OFF.
- If the power is cut off for some reasons during operation of this unit (the power code comes off and the power fails), it does not operate when the power is applied again. Turn the “POWER” switch ON again.

5-2. Temperature Control

5-2-1. setting the surface temperature of the block

The surface temperature of the calibration block is set with operation keys on the lower part of the indicator.

First, check that “SP value” is displayed on the lower row of the indicator (orange).

If an item other than “SP” (e.g. “OUT,” “P” etc.) is displayed, press “DISPLAY” at the upper right of the operation keys to set “SP value.”

(1) When you press the round “SET” key in the center, the value on the right of “SP” on the lower row of the indicator blinks.

(2) Change the value to a temperature you want to set by using the arrow keys in the center.

The value blinks during setting operation.

Finally, when you press the “SET” key, the value is lit and temperature setting is complete.

* When terminating the setting halfway, press the “DISPLAY” key at the upper right while the value is blinking. The normal display is returned.

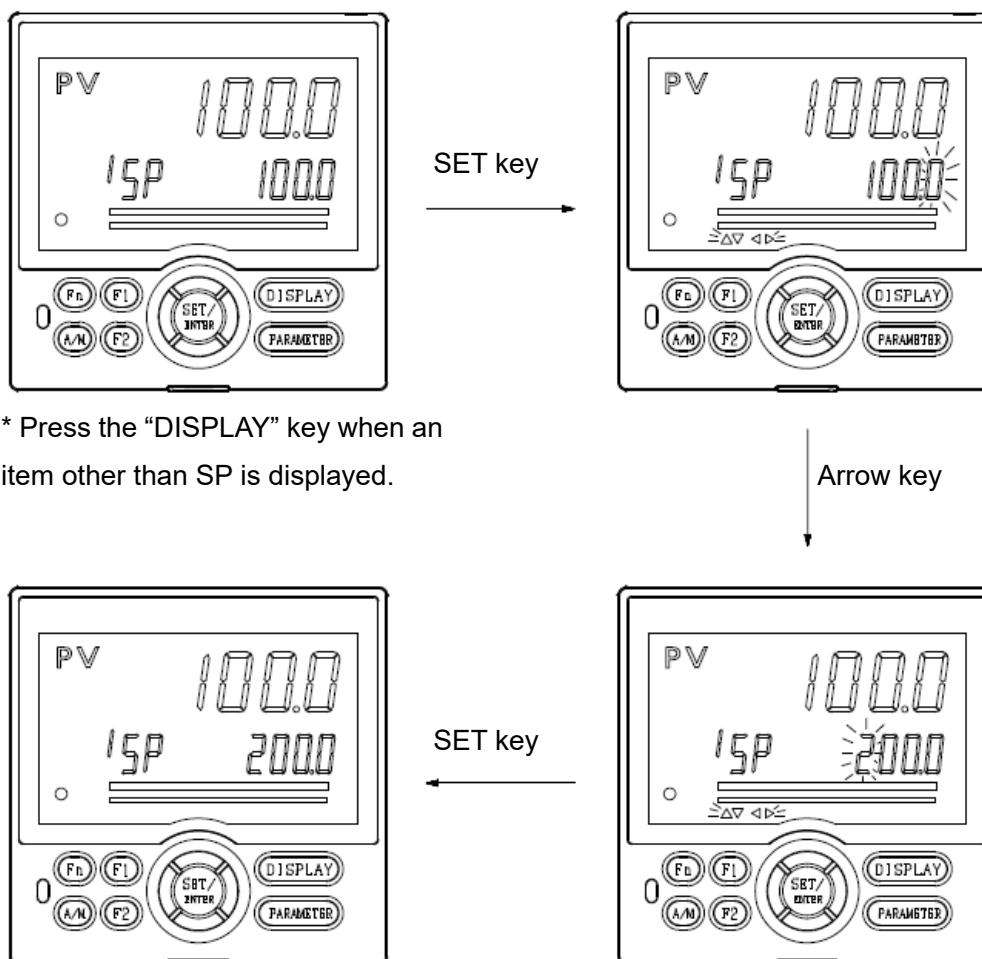

5-2-2. setting the PID values

This unit controls the temperature by PID control. There are two modes to set the PID values: auto tune mode and normal mode. Please use common auto tune mode.

- **Auto tune (Recommended mode)**

(1) Press the long “PARAMETER” key at the lower right for three seconds. When “OPE.M MOdE” is displayed on the lower row of the indicator, press the “SET” key.

(2) When the “R.L LCL” is displayed on the lower row of the indicator, select “At OFF” with the down key of the arrow keys.

When you press the “SET” key, “OFF” blinks.

(3) Change the indication to “At 1” by using the up key of the arrow keys.

(4) When you press the “SET” key, the lower row of the indicator is switched to “OUT 0.0”. The red luminescence at the lower left blinks to start auto tune.

(5) When the red luminescence stops blinking, auto tune is complete.

* When you want to terminate auto tune half way, cancel it by changing “At 1” in (3) to “At OFF.”

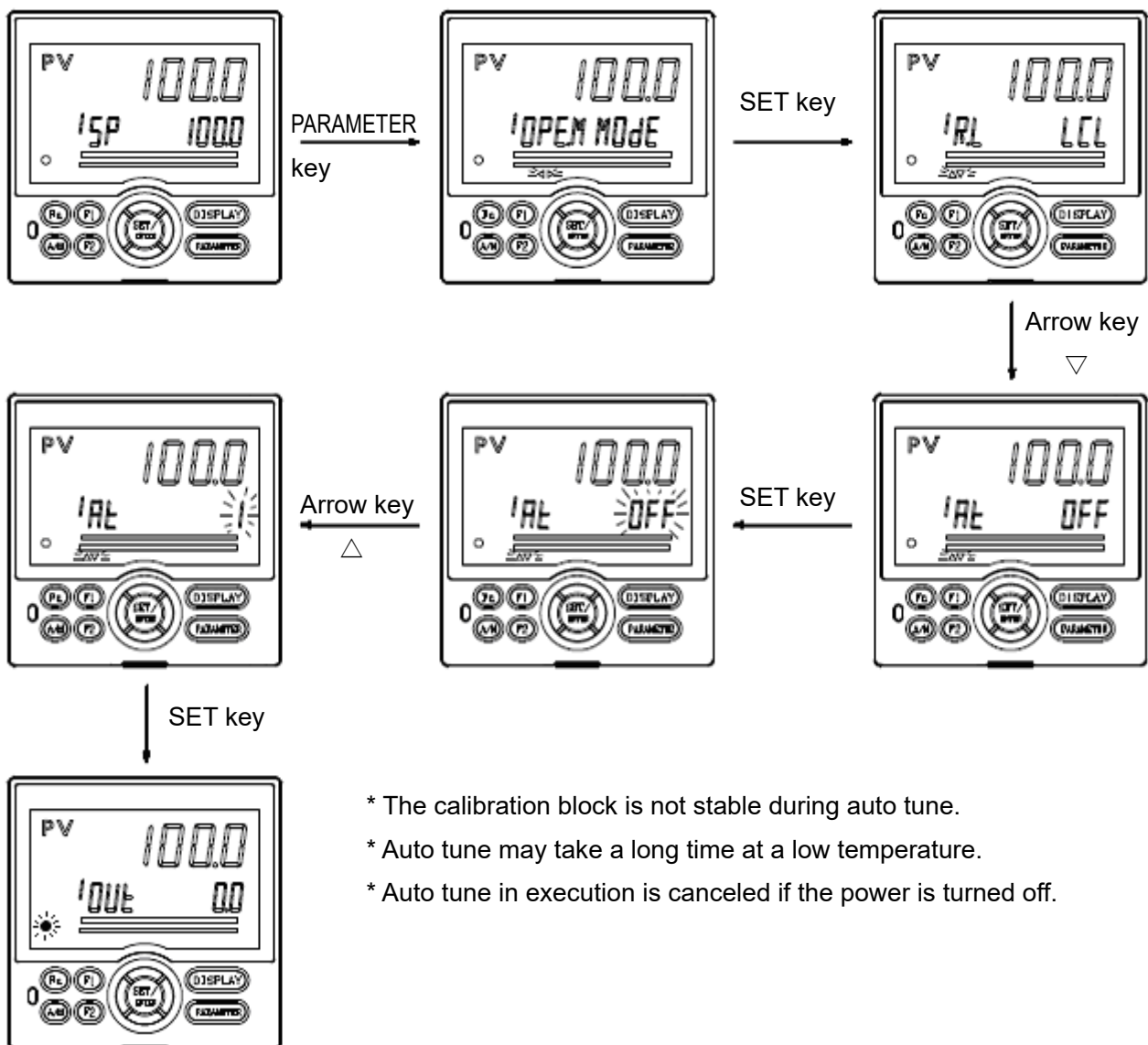

- * The calibration block is not stable during auto tune.
- * Auto tune may take a long time at a low temperature.
- * Auto tune in execution is canceled if the power is turned off.

● **Manual PID setting mode**

(1) When you press the “Fn” key at the upper left, “P value” is displayed on the lower row of the indicator.

(2) When you press the “SET” key, the value blinks. Then change the value by using the arrow keys.

(3) Press the “SET” to light the value. The setting is complete.

(4) When you press the down key of the arrow keys while “P value” on the lower row of the indicator is blinking, “P value” is changed to “I value” and then “D value.” Change each value by following the operation procedures (2) and (3) above.

* Do not change the values or parameters except on the P/I/D screens. See the next page.

(5) Press the “Fn” key after the setting is complete. The normal display is returned.

* When terminating the setting halfway, press the “DISPLAY” key at the upper right while the value is blinking. The normal display is returned.

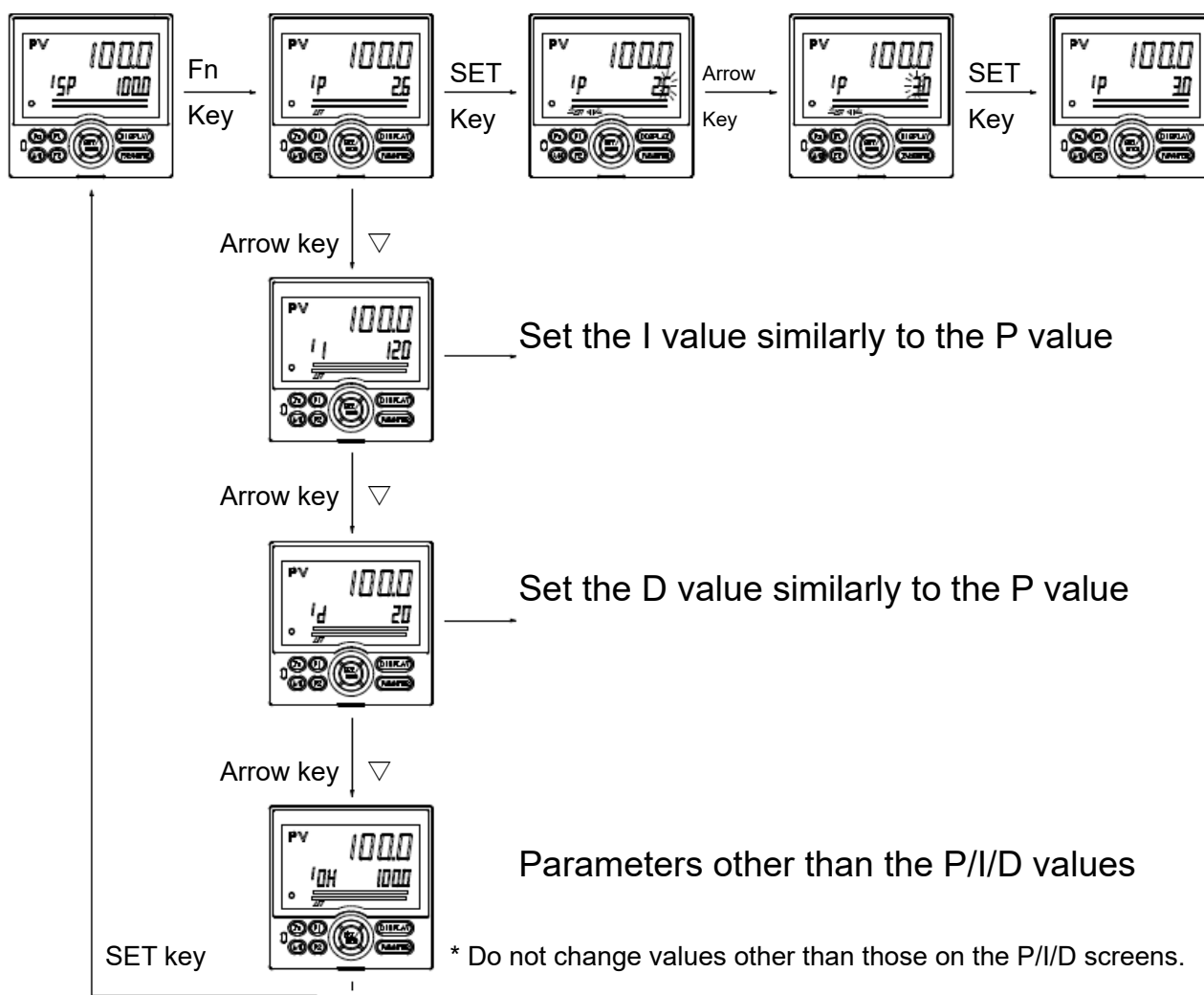

—CAUTION—

* With the operation key “Fn,” the following parameters can be changed.

When you press the “Fn” key, “P value” appears first.

The parameters are switched in turn by up/ down key operation.

“P”→“I”→“D”→“OH”→“OL” . . . “PO”→“END”→“P” (returned to the initial state)

Never change the settings other than the “P/I/D” values.

If the displayed values of parameters are different from those shown below, stop using the unit and contact us.

PID parameters switched with the Fn key and setting conditions

Parameter	Value	Description	Setting *Do not make a change.
P	2.0	Proportional band	Reference 100°C : 2.5 300°C : 2.0 500°C : 1.8
I	170	Integral time	Reference 100°C : 300 300°C : 170 500°C : 130
D	40	Derivative time	Reference 100°C : 80 300°C : 40 500°C : 30
OH	100.0	Upper limit of heating control 100.0%	*Never make a change.
OL	0.0	Lower limit of heating control 0.0%	*Never make a change.
MR	50.0	Intermediate control value 50.0%	*Never make a change.
dR	RVS	Control action (reverse action)	*Never make a change.
PO	0.0	Output at the time of stop	*Never make a change.
END	END	End	

Press the “Fn” key or “DISPLAY” key to return to the normal display.

6. Calibration tutorial

6-1. Introduction

This section provides considerations and techniques to help you complete precise temperature calibrations.

6-2. Environmental Conditions

The calibration should be performed under laboratory conditions having an ambient temperature of $23\pm 5^{\circ}\text{C}$, a relative humidity of less than 70%, and an air velocity of less than 0.1m/sec.

—NOTE—

The calibration block may disturb the room temperature if the room is not well air-conditioned.

—NOTE—

You will know how the surface temperature is sensitive to the air flow if you blow on the surface.

6-3. Warm Up

Most equipment is subject to at least a small amount of drift when it is first turned on. To ensure long-term calibration accuracy, turn on the power to the ACS II and allow it to warm up for at least two hours before beginning the calibration procedure.

WARM-UP / COOL-DOWN RATE

MODEL	ACS II – 1000	ACS II – 2000
Room Temp. → 150°C	25 min	25 min
Room Temp. → 300°C	50 min	30 min
Room Temp. → 500°C	-----	60 min
500 °C → 250°C	-----	20 min *
300 °C → 150°C	80 min *	90 min *
300 °C → 50°C	140 min *	150 min *

* compulsive cooling(by Cooling-Unit)

6-4. Calibration Probe

Most of ANRITSU surface probes are designed to be pressed perpendicular to the surface.

—CAUTION—

Air probes and liquid probes cannot be calibrated by the ACS II -1000 and ACS II -2000.

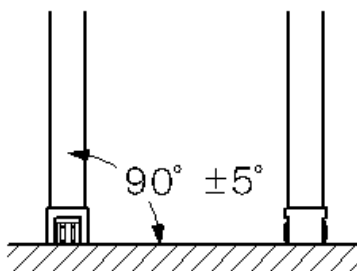

—CAUTION—

Check the sensor part of the probe before the calibration. The probe shows much error if the sensor part is deformed. Do not touch the sensor part of the probe.

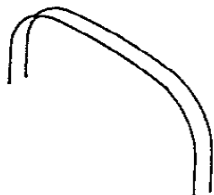

Normal

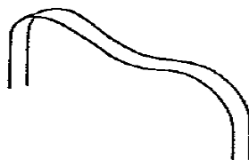

Deformed



Deformed



Deformed

—CAUTION—

Do not make a scratch on the surface of calibrator.

Press the probe softly. (Approx. 20~400g)

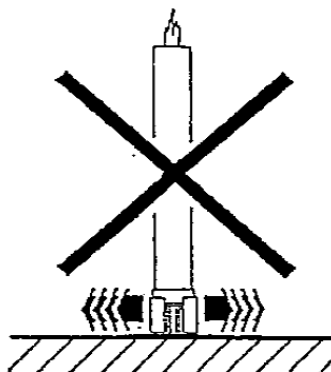

7. Specifications

● Overall Accuracy

MODEL		ACS II – 1000	ACS II – 2000
Calibration Object		Surface Temperature	Surface Temperature
Range (°C)	Room Temp to 100	+0.5 / -0.7	+0.5 / -0.7
	100 to 200	+0.5 / -1.1	+0.5 / -1.1
	200 to 300	+0.5 / -1.5	+0.5 / -1.5
	300 to 400	-----	+0.4 / -2.0
	400 to 500	-----	-0.1 / -2.9

● Control Unit

MODEL		ACS II – 1000	ACS II – 2000
Range		Room Temp. to 300°C	Room Temp. to 500°C
Control Principle		PID Auto - Tuning Control	
Control	Input Accuracy Display	Pt 100 ϕ 3.2 , Class A (0.2% of reading) °C 8mm high LED display	
Power Consumption		App. 250 W	App. 1100 W
Dimensions		320 (W) x 177 (H) x 350 (D) mm	
Weight		4.5 kg	

● Calibration Unit

MODEL		ACS II – 1000	ACS II – 2000
Test Surface		Φ 78 mm	Φ 100 mm
Temp. Distribution		Less than \pm 0.1 °C	
Heater		150 W	600 W
Dimension		260 x 130 x 260 mm	390 x 360 x 230 mm
Weight		7 kg	20 kg